



# Green Ship Technology Cocktail

Atomium, 30<sup>th</sup> of November 2010

## Green Ship Technology Book

EXISTING TECHNOLOGY BY THE MARINE EQUIPMENT INDUSTRY:  
A CONTRIBUTION TO THE REDUCTION  
OF THE ENVIRONMENTAL IMPACT OF SHIPPING



Ernst Christoph Krackhardt –  
Chairman of EMEC Working Group for Climate Change and Environment

- Shipping carries > 80% of global transport
- Emissions from ships are comparatively small (3%), but in focus
- MARPOL 73/78 is the most important set of international rules dealing with the environment and the mitigation of ships pollution

- Examples of legislation in place to reduce the environmental impact of shipping:
  - SECA
  - International Ballast Water Convention to be ratified (Ballast Water Treatment Systems)
  - Coatings Legislation (REACH, Biocidal Products Directive, etc.)
  - Helcom
  - MARPOL 73/78
- Deployment of ‘green technologies’:
  - More incentives needed to stimulate investment and promote profit maximisation
- Retrofitting of existing technologies being researched / becoming more attractive

- The environmental footprint of shipping has been significantly improved by Ship-owners through inputs from the marine equipment industry, in particular from the European marine equipment sector
- Marine equipment manufacturers have to maintain levels of investment for new technologies, as future regulation for 'greening' of shipping is likely to be adopted at international level in ever challenging demands.
- Platform life (ship) is getting significantly longer than regulations' lifespan



**Cost-Saving Solutions**



**Reduced Energy Costs**



**Highest Reliability and Availability**



**Optimised Lifecycle - Costs**



**Environmental Compatibility**

# Effective Fuel

Possible scenario for the development of fuel costs with consideration of future environmental penalties (as for SOx and COx) - low-emission propulsion systems pay back

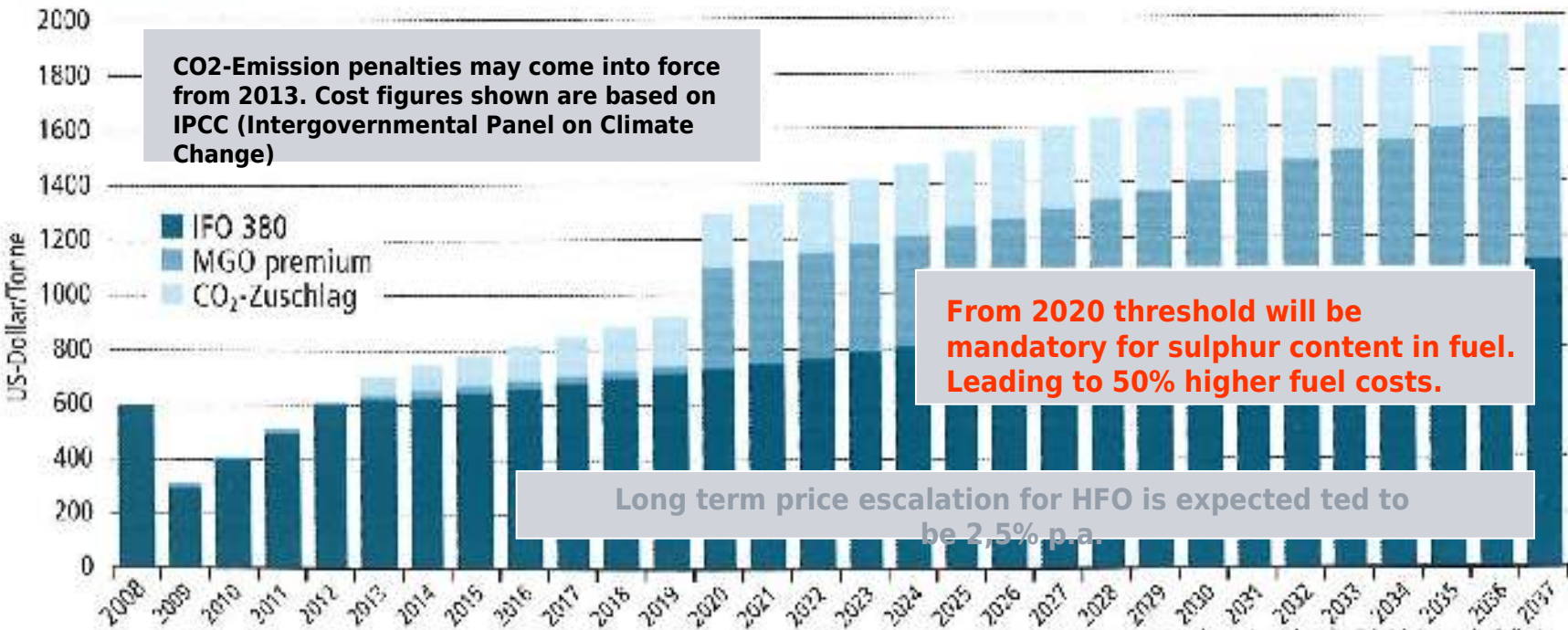

Source: Germanischer Lloyd

One possible approach is offered by the practical Green Technology Book from EMEC, aiming to provide the reader a look at currently existing green technology and its impact on the environment in a structured way.

This book allows an quick orientation on the current capabilities of technology and the potential they could achieve even above and beyond current regulatory requirements.

Each topic is dealt with in a structured way, separately and broken down into the subcategories:  
Legal Basis, Problem Statement and Possible Solutions



To download your copy please go to [www.emec.eu/green](http://www.emec.eu/green)

# Green Ship Technology Book

EXISTING TECHNOLOGY BY THE MARINE EQUIPMENT INDUSTRY:  
A CONTRIBUTION TO THE REDUCTION  
OF THE ENVIRONMENTAL IMPACT OF SHIPPING



# Gaseous Emissions

Introduction

## **Emissions**

Ship Waste  
Treatment

Bilge Water  
Treatment Systems

Black Water and  
Gray Water

Ballast Water

Underwater Coatings

Marine Equipment  
Future Green  
Technology

Developments  
Conclusions





# 1.3 CO<sub>2</sub>

**1. LEGAL BASIS:** Agreement for control of Air pollution from CO<sub>2</sub> shipping (EMEC 2016) and 2018/1832/EU, the revised Energy Efficiency Design Index (EEDI) for the maritime sector based on annual emissions being discussed in international maritime law (IMO 2018, 2019).

**2. PROBLEM STATEMENT:** CO<sub>2</sub> is one of the main greenhouse gases contributing to global warming and climate change.

**3. POSSIBLE SOLUTIONS:** CO<sub>2</sub> emissions from the maritime sector can be reduced by increasing energy efficiency, such as using alternative fuels, or by capturing CO<sub>2</sub> emissions from the ship's engine exhaust.

**Hybrid Fuel Cell System (FCV/DFCS):** A hybrid fuel cell system usually consists of a fuel cell, diesel generator and battery. The intelligent control system optimizes the loading process to provide the maximum efficiency for the fuel cell and diesel generator. Energy storage and control and other power. The discharge rate of the fuel cell is limited by the CO<sub>2</sub> flow and fuel cell efficiency.

**Range of Fuel Types:** Hydrogen, natural gas.

**Advantages/requirements:** A hybrid fuel cell system can reduce energy consumption and reduce CO<sub>2</sub> emissions. The average number could range from 10% up to 20% fuel savings. It is easy to install and maintain. The technology is a mature technology and can be used in a wide range of applications. The fuel cell has been used in other ships and could be used in a wide range of applications. The fuel cell has been used in other ships and could be used in a wide range of applications. The fuel cell has been used in other ships and could be used in a wide range of applications.

For further details of EMEC members visit [www.emec.org](http://www.emec.org)

**Microbial Fuel Cell:** A hybrid fuel cell system that uses a microbial fuel cell (MFC) to generate electricity. The MFC uses bacteria to break down organic matter (such as wastewater) and produce electricity. The MFC can be used to power small-scale applications, such as remote monitoring stations.

**Wind Powering:** A hybrid fuel cell system that uses a wind turbine to generate electricity. The wind turbine can be used to power small-scale applications, such as remote monitoring stations.

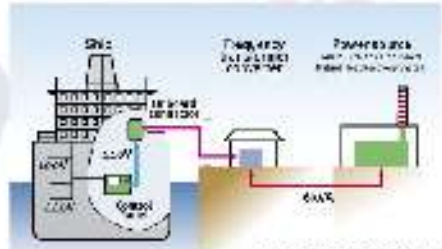
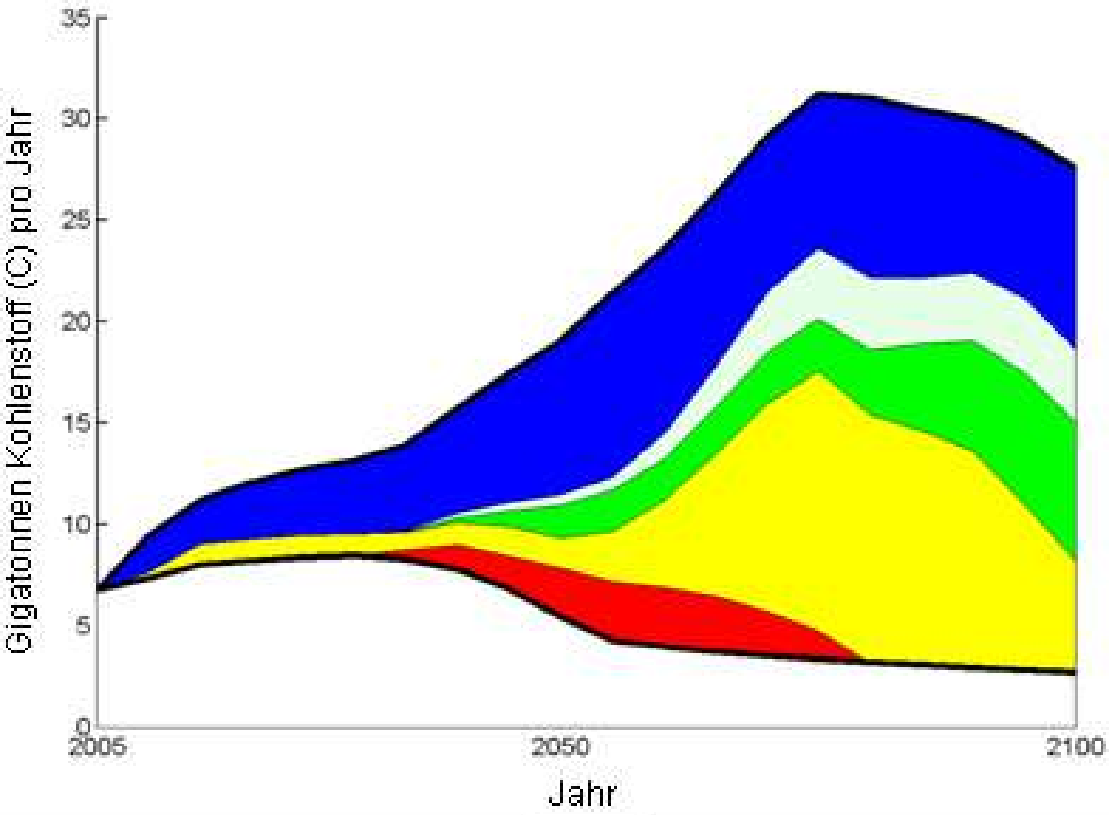

Figure 1: Hybrid fuel cell system

**Hydrogen Fuel Cell System:** A hybrid fuel cell system that uses a hydrogen fuel cell to generate electricity. The hydrogen fuel cell uses hydrogen gas and oxygen to produce electricity. The hydrogen fuel cell can be used to power small-scale applications, such as remote monitoring stations.

**High Efficiency Microbial Fuel Cell:** A hybrid fuel cell system that uses a high efficiency microbial fuel cell (MFC) to generate electricity. The MFC uses bacteria to break down organic matter (such as wastewater) and produce electricity. The MFC can be used to power small-scale applications, such as remote monitoring stations.



- Nuclear
- Renewables
- Biomass + CCS
- Fossile + CCS
- Efficiency

Assumptions:  
Coal/oil/gas low price (2005)

Energiebedingte Emissionen

Source: Potsdam Institut für Klimaforschung / Forschungsbereich Nachhaltige Lösungen

## Emission reduction

**Higher efficiency  
=  
Lower emissions in general**

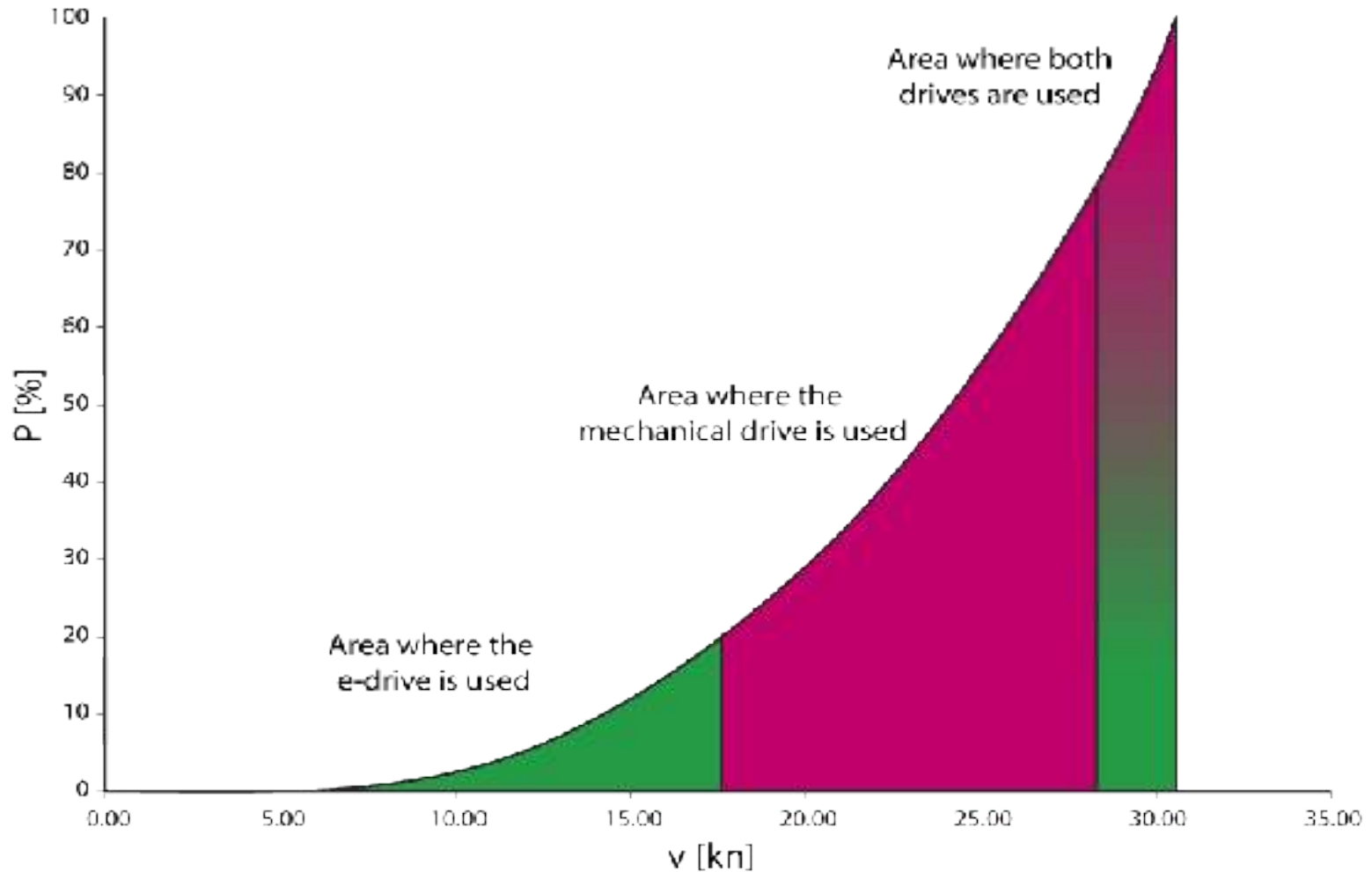

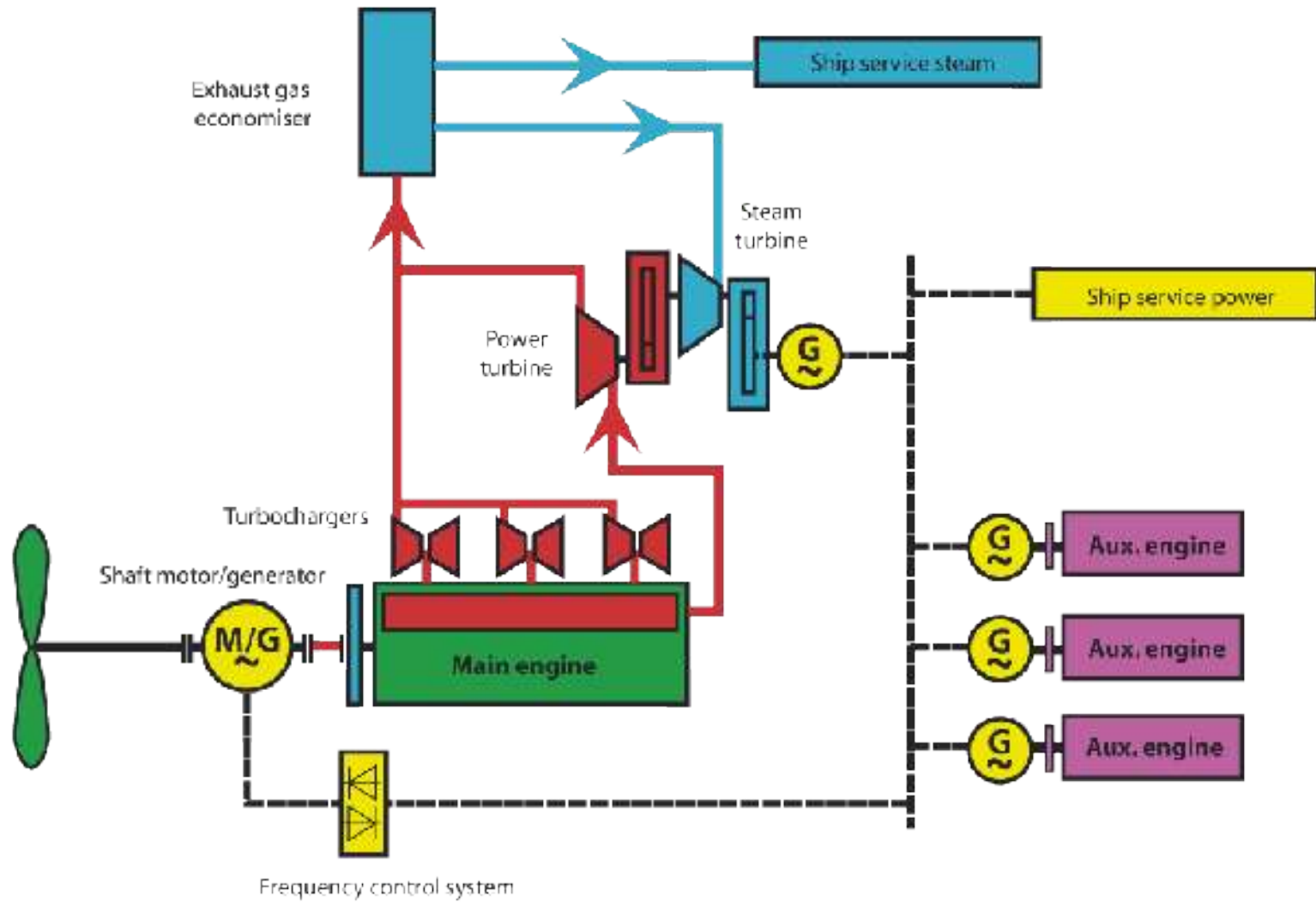

# You can stop 500'000 tons of CO2 emissions from happening per vessel with waste heat recovery \*

\* 12RT-flex96C running at 85% load for 6000 hours per year

10% fuel saving with heat recovery

20 years vessel lifetime cycle

# Strategic Perspective: Future LCM

Full Life Cycle Considerations suggest a modified approach

- Service
  - Predictive Maintenance
  - Planned Maintenance
  - Unplanned Maintenance
  - Spareparts & Logistics
- Migration
  - Modernization
  - Retrofit
  - Upgrade
- Value keeping
  - Energy / Emission Management
  - Technical condition surveys

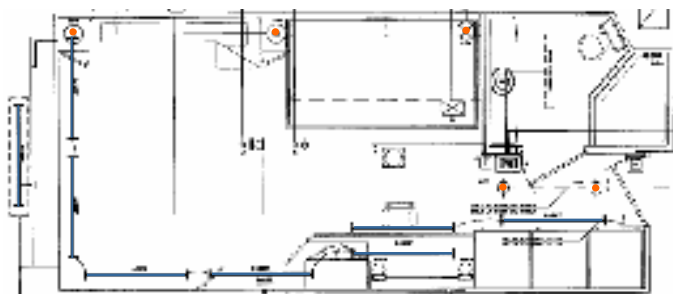

ACTUAL INVENTORY	IMPROVED (one-to-one replacement)	IMPROVED (new design)
exterior fluorescent lamp L36W (1 piece)	exteriour fluorescent lamp Lumilux F4 Y 36W (1 piece)	exteriour fluorescent lamp Lumilux T5 HE 14W (1 piece)
fluorescent lamp L 36W CCG (7 pieces)	fluorescent lamp Lumilux T5 FH 21W ECG (7 pieces)	compact fluorescent lamp DULUX D/E 13W ECG (4 pieces)
compact fluorescent lamp Dulux D 10W CCG (2 pieces)	compact fluorescent lamp Dulux D/E 10W ECG (2 pieces)	halogen lamp DECOSTAR 20W IRC (2 pieces)
incandescent lamp CLAS B 40W (3 pieces)	compact fluorescent lamp Dulux EL Classic 9W (3 pieces)	compact fluorescent lamp Dulux EL Classic 9W (2 pieces)

Connected Cabin Load  
one-to-one replacement

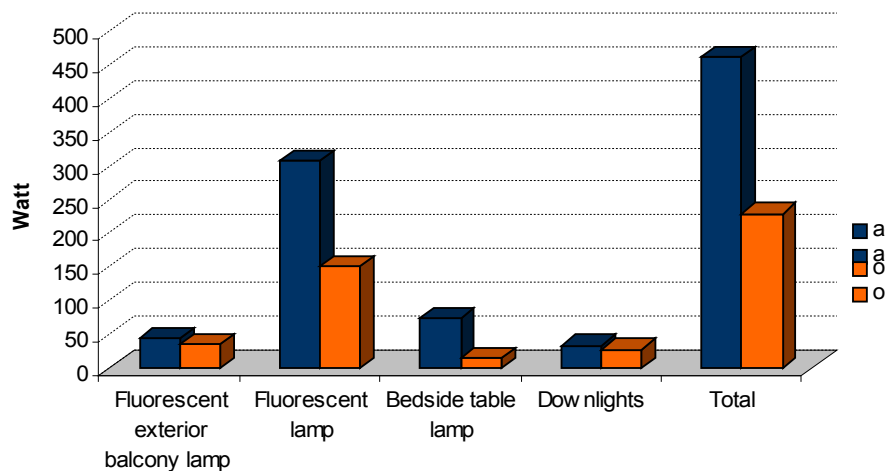

Connected Cabin Load  
new design

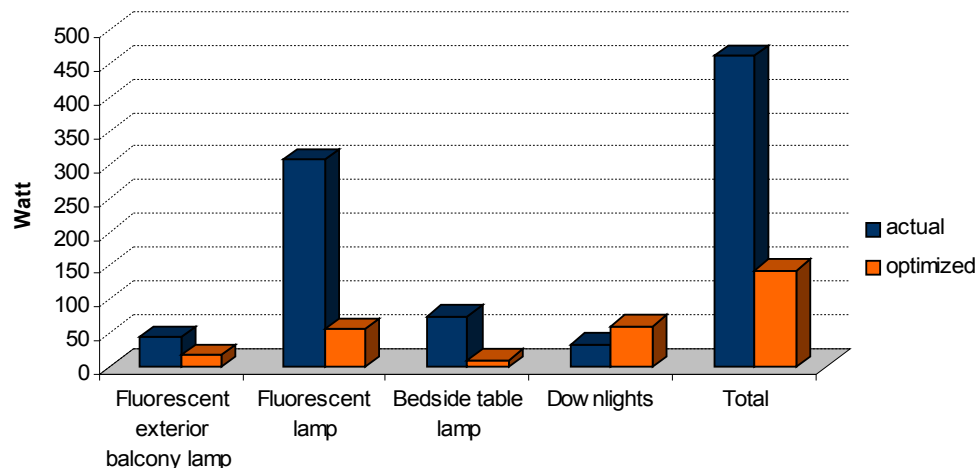

# Further Chapters

**Introduction**

**Emissions**

**Ship Waste  
Treatment**

**Bilge Water  
Treatment  
Systems**

**Black Water and  
Gray Water**

**Ballast Water**

**Underwater  
Coatings**

**Marine Equipment  
and Future Green  
Technology  
Developments**

**Conclusions**



- Develop/improve on the fuel topic, i.e. combustion characteristics and emissions, fuel processing, supply and storage of alternative fuels for cost reduction and environmental footprint benefits.
- A holistic approach to energy and waste management needs to be developed. We must explore the energetic interactive utilisation and the use of renewable materials and re-cycling.
- Smart system modeling tools are required to analyse the performance of various propulsion options for different ship designs, operating characteristics and whole product cycle environmental impact and cost in order to optimise the design at system level.

- Radical changes in the powering and propulsion of ships will be necessary to meet the current and future environmental legislation.
- New cost effective ship designs, optimised for European (coastal) routes need to be developed (“from road to the sea”).
- The European marine equipment industry needs to keep its holistic cutting-edge technology level to generate benefit for both the maritime transport industry and the environment.

# What Next...?

# Thank You for Your Attention

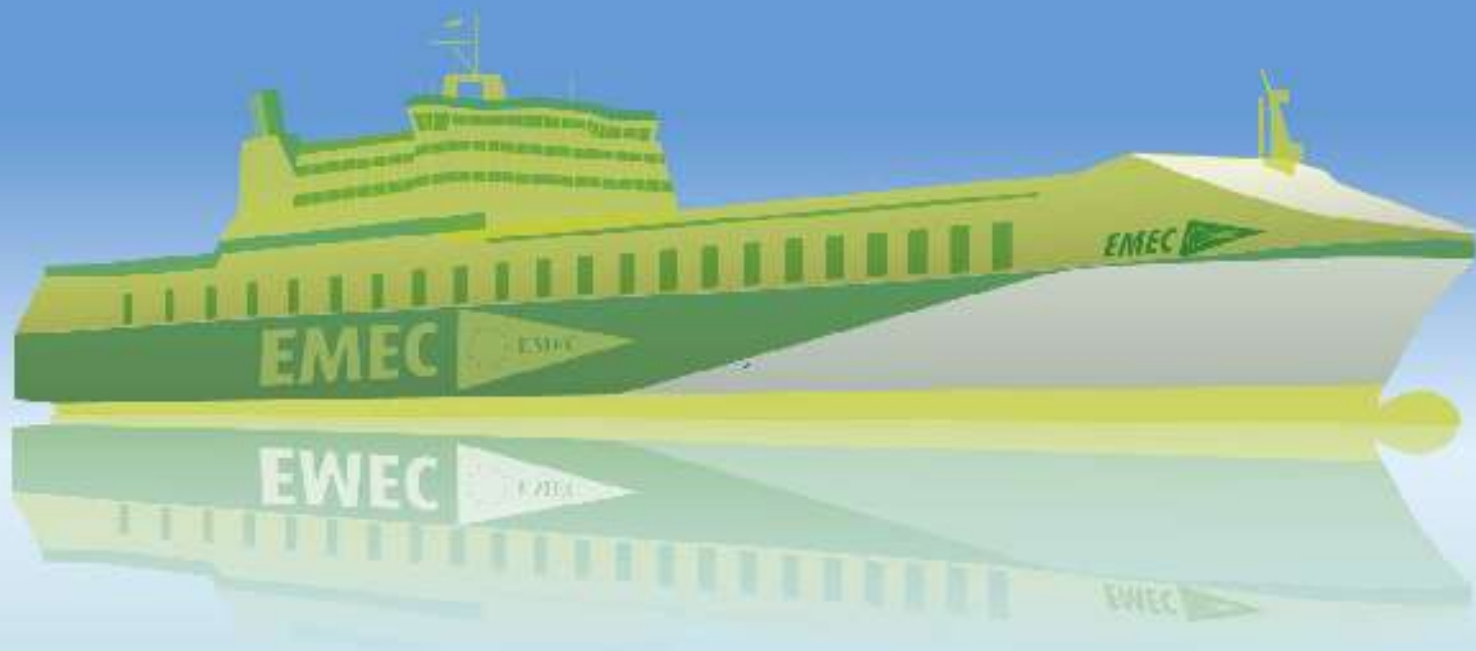

For Further Information Please Contact the EMEC Secretariat:

EMEC

Rue Belliard 159

1040, Brussels

Belgium

Tel: +32 2 230 9064

Email: [info@emec.eu](mailto:info@emec.eu)